

# GSB772S

## PNP EPITAXIAL PLANAR TRANSISTOR

### Description

The GSB772S is designed for using in output stage of 0.75W amplifier, voltage regulator, DC-DC converter and driver.

### Package Dimensions

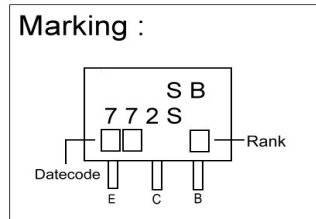
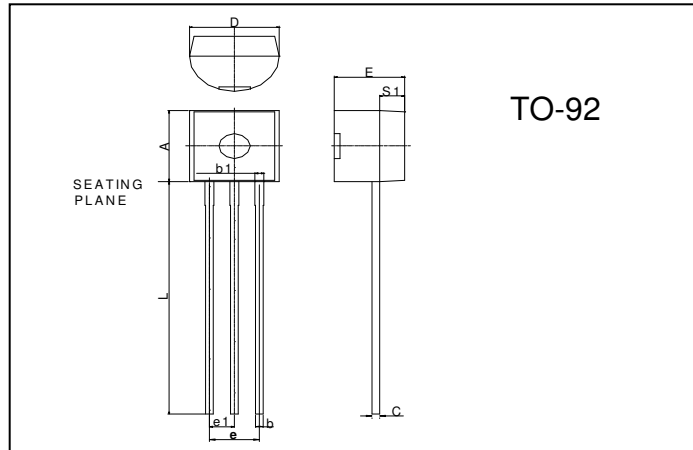

REF.	Millimeter		REF.	Millimeter	
	Min.	Max.		Min.	Max.
A	4.45	4.7	D	4.44	4.7
S1	1.02	-	E	3.30	3.81
b	0.36	0.51	L	12.70	-
b1	0.36	0.76	e1	1.150	1.390
C	0.36	0.51	e	2.42	2.66

### Absolute Maximum Ratings at Ta = 25°C

Parameter	Symbol	Ratings	Unit
Junction Temperature	Tj	+150	°C
Storage Temperature	Tstg	-55 ~ +150	°C
Collector to Base Voltage at Ta=25°C	VCBO	-40	V
Collector to Emitter Voltage at Ta=25°C	VCEO	-30	V
Emitter to Base Voltage at Ta=25°C	VEBO	-5.0	V
Collector Current at Ta=25°C	IC	-3.0	A
Total Power Dissipation at Ta=25°C	PD	750	mW

### Characteristics at Ta = 25°C

Symbol	Min.	Typ.	Max.	Unit	Test Conditions
BVCBO	-40	-	-	V	IC=-100uA
BVCEO	-30	-	-	V	IC=-10mA
BVEBO	-5	-	-	V	IE=-10uA
ICBO	-	-	-1	uA	VCB=-30V
IEBO	-	-	-1	uA	VEB=-3V
*VCE(sat)	-	-0.3	-0.5	V	IC=-2A, IB=-0.2A
*VBE(sat)	-	-1	-2	V	IC=-2A, IB=-0.2A
*hFE1	30	-	-		VCE=-2V, IC=-20mA
*hFE2	100	160	500		VCE=-2V, IC=-1A
fT	-	80	-	MHz	VCE=-20V, IC=-20mA, f=100MHz
Cob	-	55	-	Pf	VCB=-10V, f=1MHz

\*Pulse Test: Pulse Width ≤ 380us, Duty Cycle ≤ 2%

### Classification Of hFE2

Rank	Q	P	E
Range	100-200	160-320	250-500

## Characteristics Curve

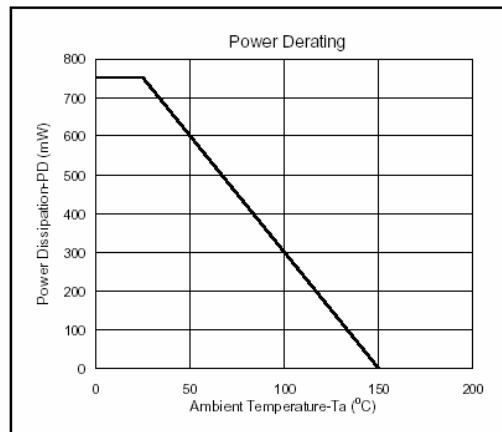
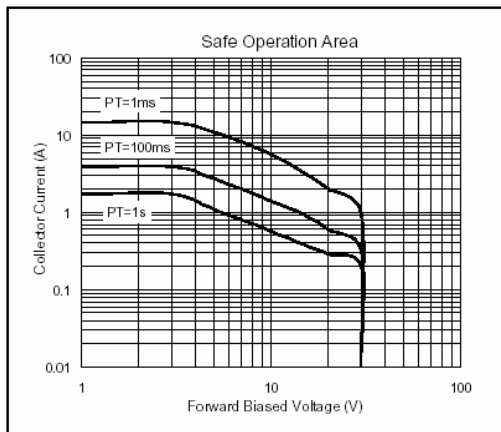
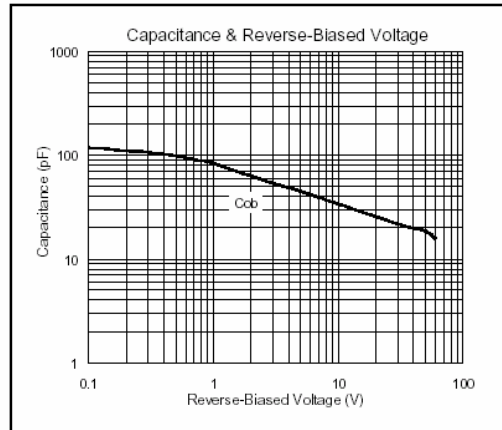
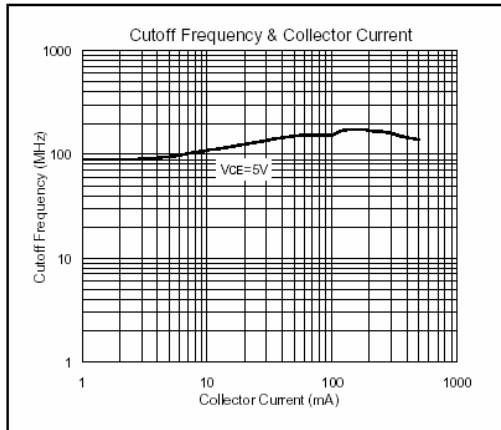

**Important Notice:**

- All rights are reserved. Reproduction in whole or in part is prohibited without the prior written approval of GTM.
- GTM reserves the right to make changes to its products without notice.
- GTM semiconductor products are not warranted to be suitable for use in life-support Applications, or systems.
- GTM assumes no liability for any consequence of customer product design, infringement of patents, or application assistance.

**Head Office And Factory:**

- **Taiwan:** No. 17-1 Tatung Rd. Fu Kou Hsin-Chu Industrial Park, Hsin-Chu, Taiwan, R. O. C.
- TEL : 886-3-597-7061 FAX : 886-3-597-9220, 597-0785
- **China:** (201203) No.255, Jang-Jiang Tsai-Lueng RD. , Pu-Dung-Hsin District, Shang-Hai City, China
- TEL : 86-21-5895-7671 ~ 4 FAX : 86-21-38950165