

DATE OF ISSUE : 2007. 09. 29

# SPECIFICATION

MODEL : SLHNNWH629T1

HIGH POWER LED PKG -SUNNIX6

CUSTOMER : \_\_\_\_\_

SAMSUNG ELECTRO-MECHANICS		
DRAWN	CHECKED	APPROVED

CUSTOMER		
CHECKED	CHECKED	APPROVED

**SAMSUNG ELECTRO-MECHANICS CO.,LTD.**  
314, MAETAN3-DONG, YEONGTONG-GU,  
SUWON, GYEONGGI-DO,KOREA,443-743

## Contents

<b>1. Product outline</b>	.....	<b>3</b>
<b>2. Absolute Maximum Rating</b>	.....	<b>3</b>
<b>3. Characteristics</b>	.....	<b>3</b>
<b>4. Chromaticity Diagram</b>	.....	<b>4</b>
<b>5. Typical Characteristic Graph</b>	.....	<b>5</b>
<b>6. Package Outline Dimension</b>	.....	<b>6</b>
<b>7. Solder Conditions</b>	.....	<b>7</b>
<b>8. Precaution for Use</b>	.....	<b>8</b>
<b>9. Revision History</b>	.....	<b>9</b>

## ■ Product Outline

### □ Features

- Plastic Molded Lead Frame Type (8.0 × 8.0 × 3.9mm<sup>3</sup>)
- High Luminous Intensity & CRI LED
- Built In 9 LED Chips
- Beam View Angle( $\Delta\theta$ ) : 120°
- Lead(Pb) Free Product - RoHS Compliant

### □ Applications

- General Illumination  
Down Lighting  
Decorative Lighting

## ■ Rating and Characteristics

### □ Absolute Maximum Rating(Ta=25°C)

Parameter	Symbol	Rating	Unit
Reverse Voltage	V <sub>R</sub>	16.5	V
Operating Temperature	T <sub>opr</sub>	-40 ~ 85	°C
Storage Temperature	T <sub>stg</sub>	-40 ~ 110	°C
Soldering Temperature	T <sub>sol</sub>	260(for 5 second)	°C
Power Dissipation	P <sub>d</sub>	1.8	W
Forward Current, DC	I <sub>F</sub>	180	mA

### □ Electro-Optical Characteristics(Ta=25°C)

Parameter	Symbol	Rank	Min.	Typ.	Max.	Unit	Conditions
Reverse Voltage	V <sub>R</sub>	-	12.0	-	16.5	V	I <sub>R</sub> =10mA
Forward Voltage	V <sub>F</sub>	S0	8.9	-	11.0	V	I <sub>F</sub> =180mA
Luminous Flux	Φ <sub>V</sub>	S0	90	105	150	lm	
Color Temperature	CCT	-	5000	-	7000	K	

### Chromaticity Coordinate(CIE)

Rank	x				y				Condition
Q0	0.3128	0.3250	0.3200	0.3011	0.2864	0.2981	0.3600	0.3407	I <sub>F</sub> =180mA
R0	0.3250	0.3428	0.3471	0.3200	0.2981	0.3138	0.3818	0.3600	

※ Tolerance : V<sub>F</sub> : ±0.1, Φ<sub>V</sub> : ±10%, CC<sub>x</sub> CC<sub>y</sub> : ±0.02

## ■ Chromaticity Diagram

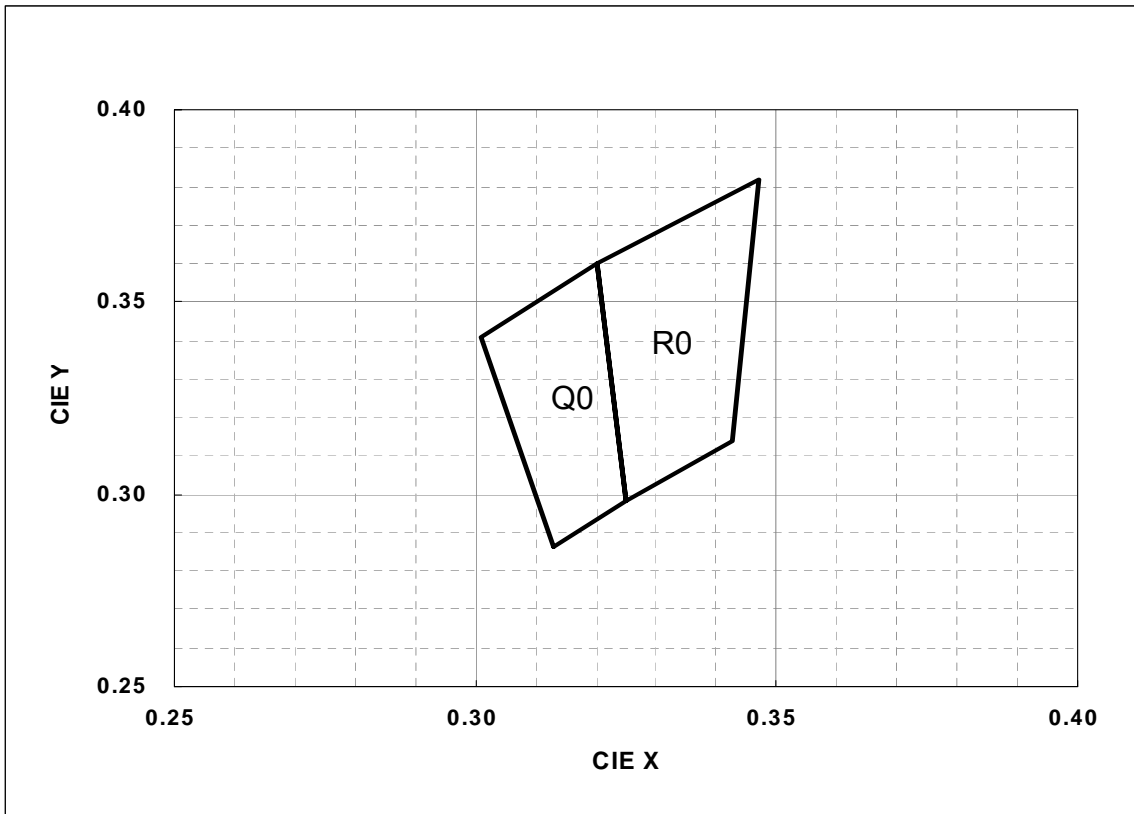

## ■ Typical Characteristics Graph

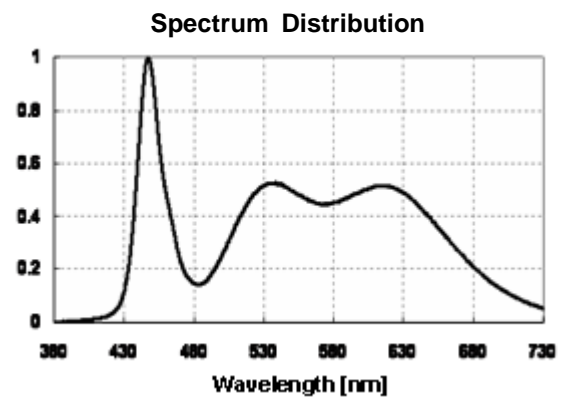
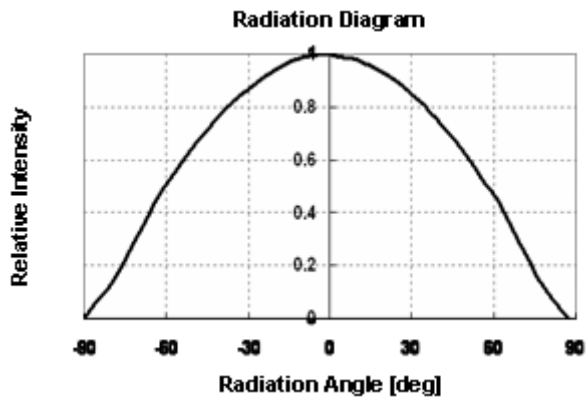
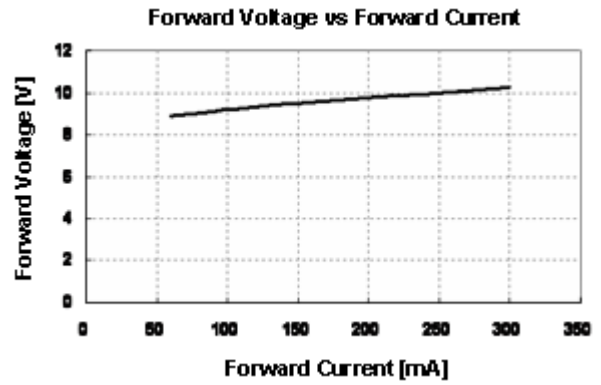
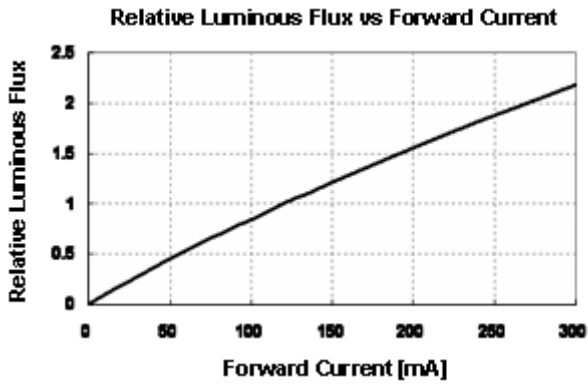

## Package Outline Dimensions

Unit:mm  
Tolerance:±0.2

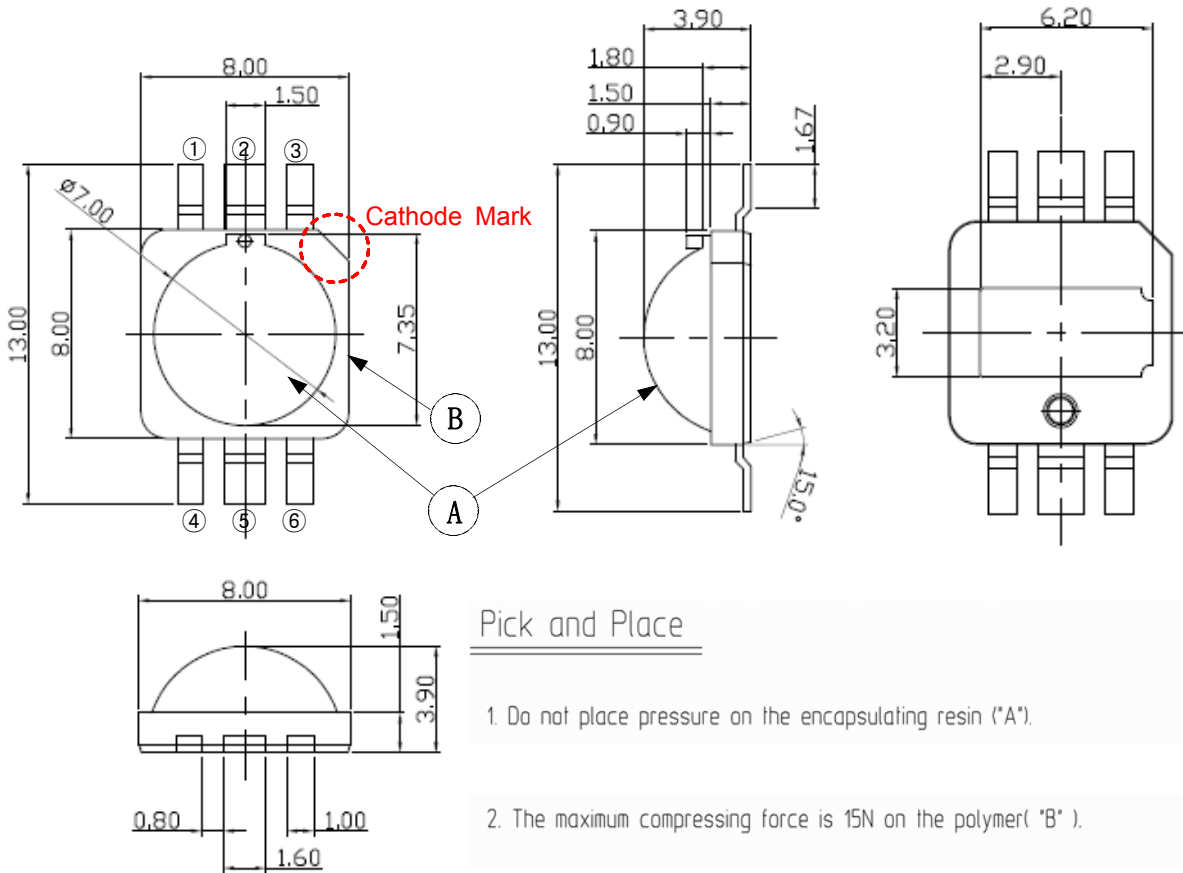

### Circuit

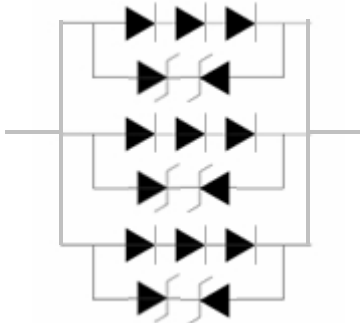

### Solder Pattern for Surface Mount

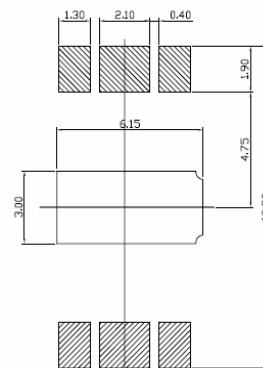

### Remarks)

- Make sure the heat sink is electrically connected to the Anode.
- Heat sink is to be soldered, If not, use the heat conductive adhesive

## ■ Solder Conditions

### 1) Reflow Conditions ( Pb-Free Solder, Sn-Ag-Cu Series recommended)

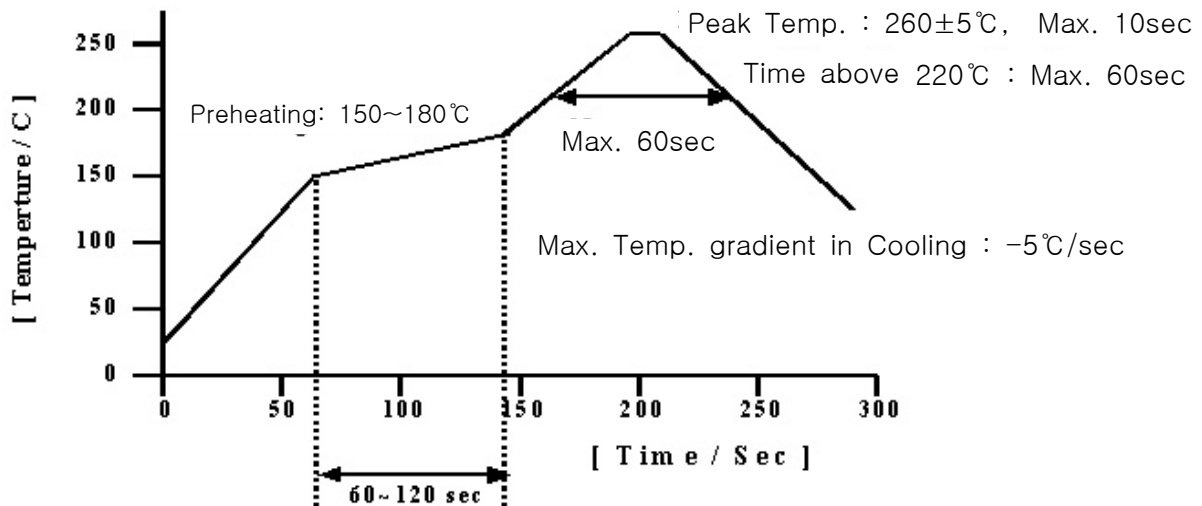

### 2) For Manual Soldering

Not more than 5 seconds @MAX300°C, under soldering iron.

## ■ Precaution for Use

- 1) For over-current-proof function, customers are recommended to apply resistors to prevent sudden change of the current caused by slight shift of the voltage.
- 2) This device should not be used in any type of fluid such as water, oil, organic solvent, etc.  
When washing is required, IPA is recommended to use.
- 3) When the LEDs illuminate, operating current should be decided after considering the ambient maximum temperature.
- 4) LEDs must be stored in a clean environment.  
If the LEDs are to be stored for 3 months or more after being shipped from SEMCO, they should be packed by a sealed container with nitrogen gas injected.  
(Shelf life of sealed bags : 12 months, temp. 0~40℃, 20~70%RH)
- 5) After storage bag is open, device subjected to soldering, solder reflow, or other high temperature processes must be:
  - a. Mounted within 168 hours (7 days) at an assembly line with a condition of no more than 30℃/60%RH,
  - b. Stored at <10% RH.
- 6) Repack unused Products with anti-moisture packing, fold to close any opening and then store in a dry place.
- 7) Devices require baking before mounting, if humidity card reading is >65% at 23±5℃.
- 8) Devices must be baked for 24hours at 65±5℃, if baking is required.
- 9) The LEDs are sensitive to the static electricity and surge. It is recommended to use a wrist band or anti-electrostatic glove when handling the LEDs.

If voltage exceeding the absolute maximum rating is applied to LEDs, it may cause damage or even destruction to LED devices.

Damaged LEDs may show some unusual characteristics such as increase in leak current, lowered turn-on voltage, or abnormal lighting of LEDs at low current.



## Revision History

**(Model:SLHNNWH629T1)**

Date	Revision History	Author	
		Drawn	Approved
2007.10.09	Initial Edition - Preliminary	R.S.Park	