

DATE OF ISSUE : 2006. 11. 03

# SPECIFICATION

MODEL : SLSNNBA825TS

BLUE FLASH LED

CUSTOMER : \_\_\_\_\_

*SAMSUNG ELECTRO-MECHANICS CO, .LTD.*

314. MAETAN3-DONG, YEONGTONG-KU,  
SUWON-SI, KYUNGKI-DO, KOREA, 442-743

## Contents

1. Product Outline	-----	3
2. Absolute Maximum Rating	-----	3
3. Characteristics	-----	3~4
4. Typical Characteristic Graph	-----	4
5. LED Package Outline Dimensions	-----	5
6. Reliability Test Items and Conditions		6~7
7. Solder Conditions	-----	7
8. Taping Dimension	-----	8
9. Reel Packing Structure	-----	9
10. Label Structure	--- -----	10
11. Precaution for Use	-----	11
12. Hazard Substance Analysis	-----	12~13
13. Revision History	-----	14

## ■ Product Outline

### 1) Feature

1. Lead Frame Type LED Package ( 5.2 \* 6.0 \* t 1.3mm )
2. Beam Angle (  $\Delta\theta$  : 120 ° )
3. GaN/Al<sub>2</sub>O<sub>3</sub> Chip & Long Time Reliability

### 2) Applications

- Channel letter, General lighting, Architectural lighting.....

## ■ Absolute Maximum Rating

- Operation Forward Current Per Chip..... 30 mA
- Peak Pulsed Forward Current Per Chip..... 100 mA  
(Duty 1/10 Pulse Width 10msec)
- Operating Temperature Range ( T<sub>opr</sub> ) ..... -30°C ~ 85°C
- Storage Temperature Range ( T<sub>stg</sub> ) ..... -40°C ~ 100°C

## ■ Characteristics

( Ta : 25°C )

	Rank	Symbol	Min.	Typ.	Max.	Unit	Conditions
Forward Voltage	S	V <sub>F</sub>	2.9	-	3.8	V	I <sub>F</sub> = 40mA
Luminous Intensity	S	I <sub>V</sub>	0.25	-	-	cd	
Reverse Voltage	-	V <sub>R</sub>	0.5	1.0	1.5	V	I <sub>R</sub> = 10mA

### Wavelength

Rank	Symbol	Min.	Typ.	Max.	Unit	Conditions
Q	<b>W<sub>b</sub></b>	450	-	457.5	nm	I <sub>F</sub> = 40mA
R		457.5	-	465		

\* Tolerance : V<sub>F</sub>:±0.1, I<sub>V</sub>:±10%, W<sub>D</sub>:±1nm

\* Luminous intensity measuring equipment : CAS140 B

# Typical Characteristics Graph

( Ta : 25°C )

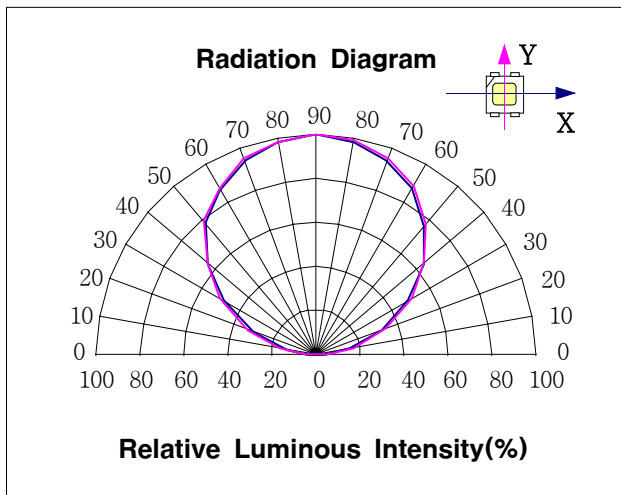
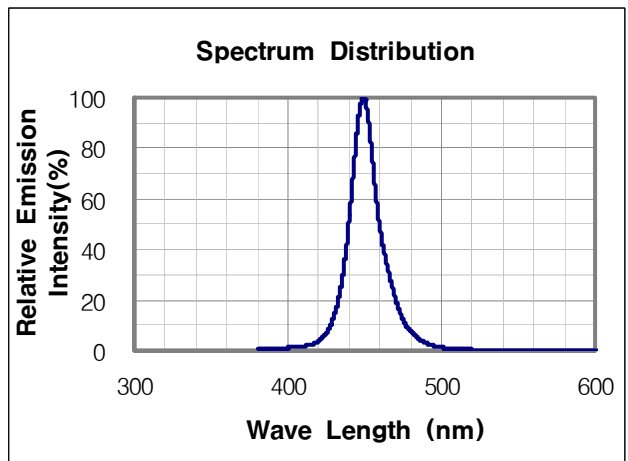
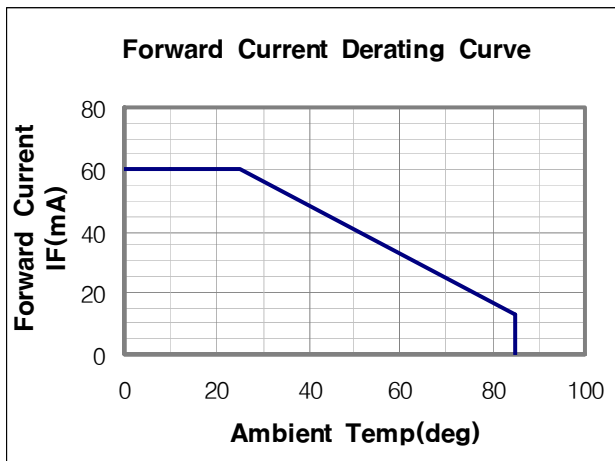
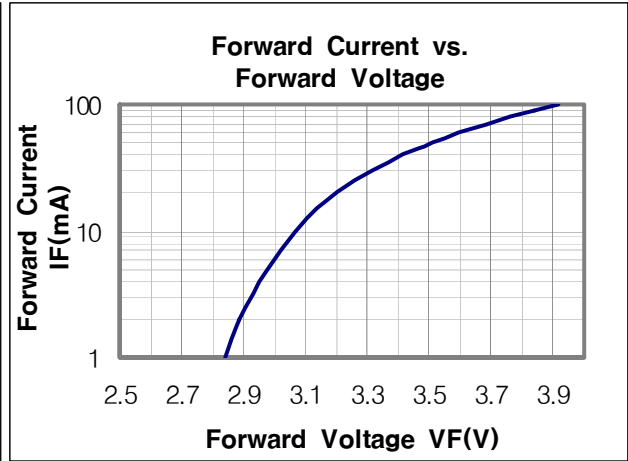
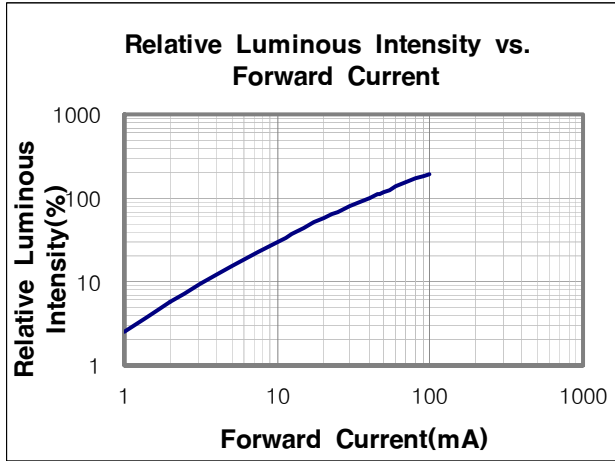

# LED Package Outline Dimensions

unit:mm

Tolerance:±0.1

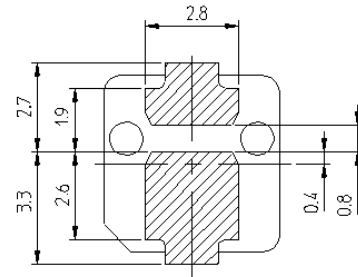
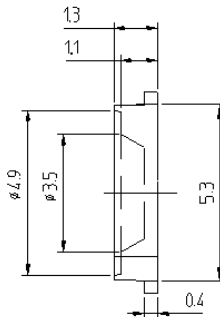
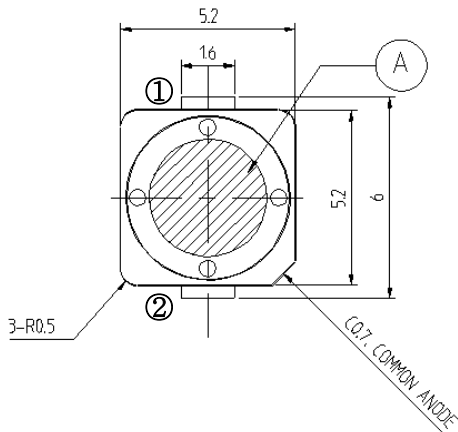

Tolerance is ±0.1mm unless otherwise noted.  
The maximum compressing pressure is 15N.  
Do not apply any damage on the phosphor ( "A" ).

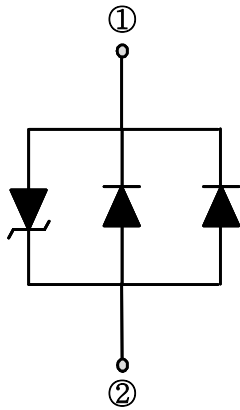

Circuit Diagram

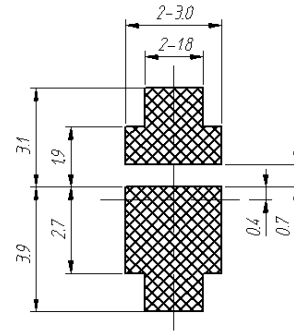

PCB PATTERN

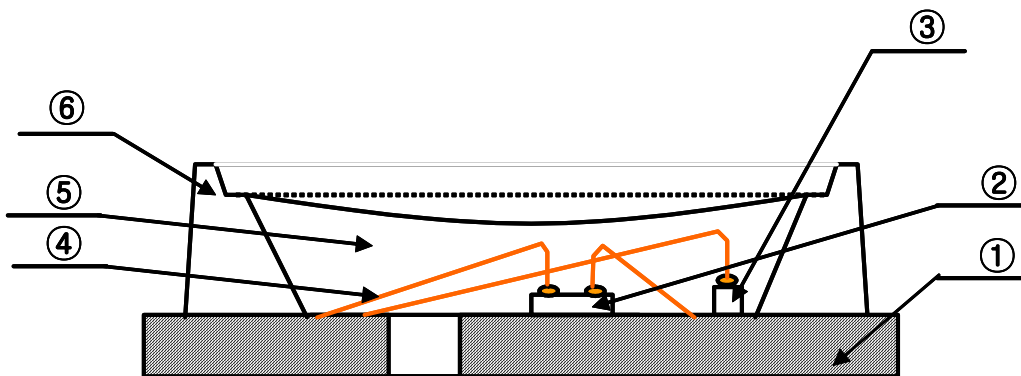

NUMBER	ITEM	MATERIAL
①	FRAME	Copper Frame(Silver Plated)
②	LED CHIP	GaN/Al <sub>2</sub> O <sub>3</sub>
③	Zener Diode	Si
④	WIRE	Gold Wire
⑤	RESIN	Resin
⑥	PACKAGE	Heat-resistant Polymer

## ■ Reliability Test Items and Conditions

### 1) Test Items

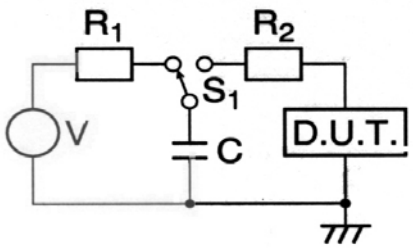
Test Item	Test Conditions	Test Hours/Cycles	Sample No
Room Temperature life test	25°C±3°C, DC60 mA	500 h	50
High Temperature humidity life test	60°C±3°C, 95%±2%RH, DC33 mA	500 h	50
High Temperature life test	85°C±3°C, DC12.5mA	500 h	50
Low Temperature life test	-30°C±3°C, DC60 mA	500 h	50
High Temperature Storage	Ta=100°C±3°C	500 h	22
Low Temperature Storage	Ta=-40°C±3°C	500 h	22
High Temperature humidity Storage	60°C±3°C, 95%±2%RH	500 h	22
Thermal Shock	-40°C ~ 100°C 0.5 h      0.5 h	100 cycles	22
Temperature humidity Cycle	25°C ~ 65°C ~ -10°C 24hrs/1cycle, 95%RH	10 cycles	22
Reflow (Pb-Free)	Peak 260±5°C for 10sec	3 times	22
ESD(HBM)	 <p>-R1:10MΩ , R2:1.5KΩ , C:100pF</p>	5 times	5
On/Off test	50°C±3°C, 95%±2%RH, DC60 mA, On/2sec, Off/2sec	108000 cycles	50

## 2) Criteria for Judging the Damage

Item	Symbol	Test Condition	Limit	
			Min	Max
Forward Voltage	V <sub>F</sub>	I <sub>F</sub> = 40mA	-	U.S.L.*1.2
Luminous Intensity	I <sub>V</sub>	I <sub>F</sub> = 40mA	L.S.L.*0.5	-

\* USL : Upper Standard Level    LSL : Lower Standard Level

## ■ Solder Conditions

### 1) Reflow Conditions ( Pb Free )

Reflow Frequency : 2 times max.

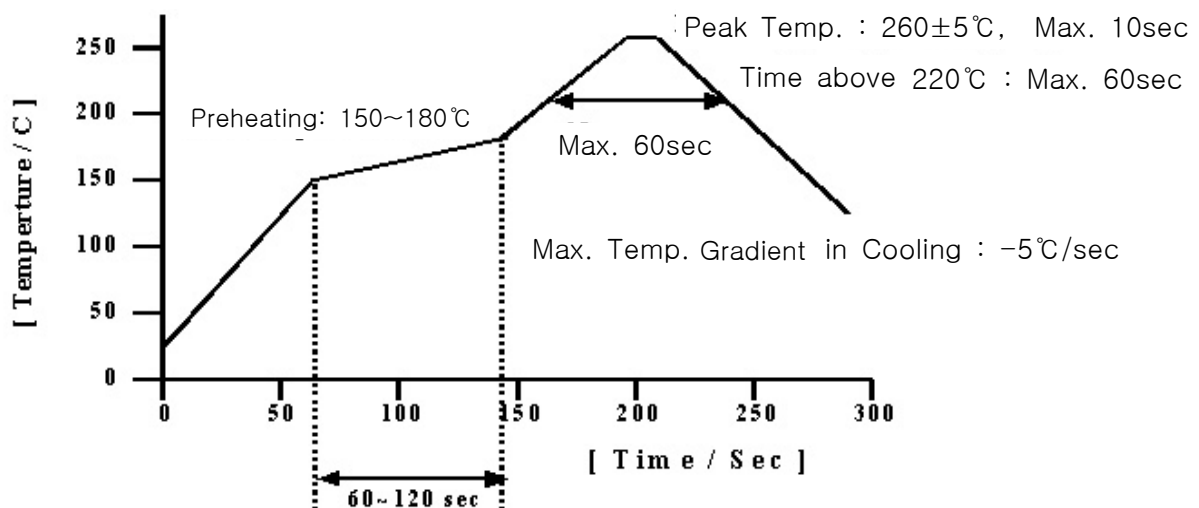

### 2) For Manual Soldering

Not more than 5 seconds @MAX300°C, under soldering iron.

## ■ Taping Dimension

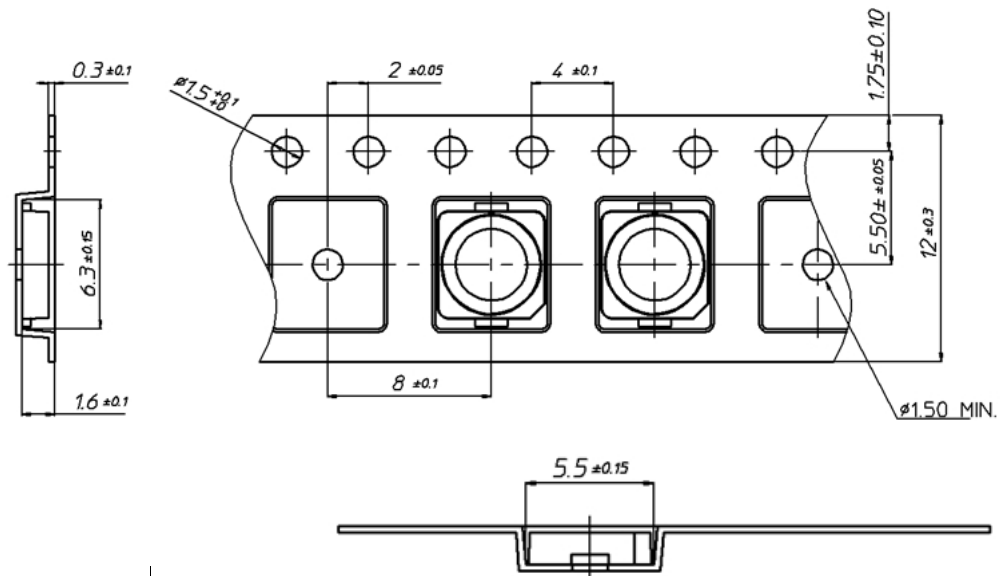

End

Start

More than 40 mm  
Unloaded tape

Mounted with  
Flash LED

More than (100~200)mm  
Unloaded tape

Leading part more than  
(200~400)mm

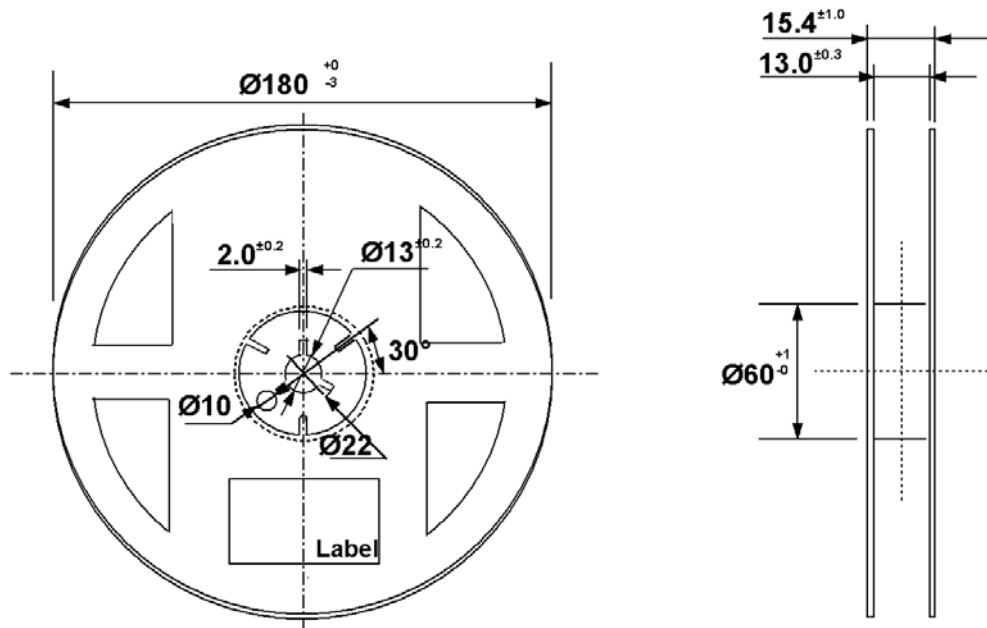

Tolerance  $\pm 0.2$  , Unit:mm

- (1) Quantity : The quantity/reel to be 1000pcs.
- (2) Cumulative Tolerance : Cumulative tolerance/10 pitches to be  $\pm 0.2$  mm
- (3) Adhesion Strength of Cover Tape : Adhesion strength to be 0.1–0.7N when the cover tape is turned off from the carrier tape at  $10^\circ$  angle to be the carrier tape.
- (4) Packaging : P/N, Manufacturing data code no. and quantity to be indicated on a damp proof package.





## Label Structure

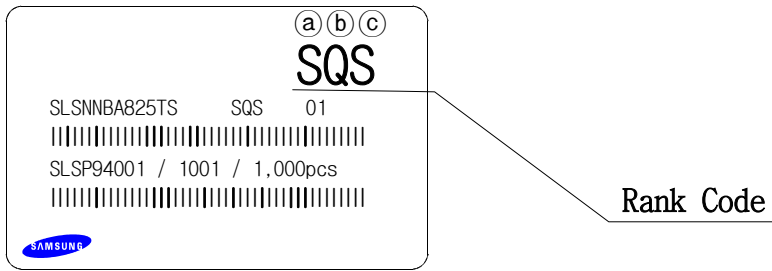

### Rank Code

- Ⓐ : VF Rank
- Ⓑ : Wavelength
- Ⓒ : IV Rank

## ■ Precaution for Use

1. This device should not be used in any type of fluid such as water, oil, organic solvent, etc.  
When washing is required, IPA should be used.
2. When the LEDs are illuminating, operating current should be decided after considering the ambient maximum temperature.
3. LEDs must be stored to maintain a clean atmosphere.  
If the LEDs are stored for 3 months or more after being shipped from Samsung Electro-Mechanics, a sealed container with a nitrogen atmosphere should be used for storage.
4. The LEDs must be used within seven days after opening the moisture proof packing. Repack unused Products with anti-moisture packing, fold to close any opening and then store in a dry place.
5. The appearance and specifications of the product may be modified for improvement without notice.
6. This LEDs is sensitive to the static electricity and surge. It is recommended to use a wrist band or anti-electrostatic glove when handling the LEDs. If over voltage which exceeds the absolute maximum rating is applied to LEDs, it will cause damage LEDs and result in destruction.

Damaged LEDs will show some unusual characteristics such as leak current remarkably increase, turn-on voltage becomes lower and the LEDs get unlighted at low current.

# ■ Hazard Substance Analysis



**Test Report No. F690501/LF-CTSGP06-21333**

Date: August 22, 2006

Page 1 of 3

To: **SAMSUNG ELECTRO-MECHANICS CO., LTD.**  
314, Maetan3-dong  
Yeongtong-gu  
Suwon-city  
KYUNGGI-DO 442-373  
Korea

The following merchandise was submitted and identified by the client as :

**Commodity** : Flash LED 5252  
**SGS File No.** : GP06-21333  
**Received Date** : August 14, 2006  
**Test Performing Date** : August 15, 2006  
**Test Performed** : SGS Testing Korea tested the sample(s) selected by applicant with following results  
**Test Results** : For further details, please refer to following page(s)

Jade Jang  
Monet Jeong  
Jully Oh  
Jerry Jung  
/Testing Person

SGS Testing Korea Co. Ltd.

Jeff Jang / Chemical Lab Mgr

This Test Report is issued by the Company subject to its General Conditions of Service printed overleaf. Attention is drawn to the limitations of liability, indemnification and jurisdictional issues defined therein. The results shown in this test report refer only to the sample(s) tested unless otherwise stated. This Test Report cannot be reproduced, except in full, without prior written permission of the Company.

SGS Testing Korea Co., Ltd. 322, The O valley, 555-9, Hoge-dong, Dongan-gu, Anyang-si, Gyeonggi-do, Korea 431-080  
t +82 (0)31 4608 000 f +82 (0)31 4608 059 www.sgslab.co.kr www.kr.sgs.com/greenlab  
1002-2, Hwasan-ri, Onsan-eub, Ulsan-gun, Ulsan, Korea 689-890 t +82 (0)52 239 8908-10 f +82 (0)52 239 6913

LAP 100

Member of SGS Group (Société Générale de Surveillance)



Test Report No. F690501/LF-CTSGP06-21333

Date: August 22, 2006

Page 2 of 3

Sample No. : GP06-21333.001

Sample Description : Flash LED 5252

Style/Item No. : N/A

#### Heavy Metals

Test Items	Unit	Test Method	MDL	Results
Cadmium (Cd)	mg/kg	US EPA 3050B(1996), US EPA 6010B(1996), ICP	0.5	N.D.
Lead (Pb)	mg/kg	US EPA 3050B(1996), US EPA 6010B(1996), ICP	5	N.D.
Mercury (Hg)	mg/kg	US EPA 3052(1996), US EPA 6010B(1996), ICP	2	N.D.
Hexavalent Chromium (Cr VI)	mg/kg	US EPA 3060A(1996), US EPA 7196A(1992), UV	1	N.D.

#### Flame Retardants-PBBs/PBDEs

Test Items	Unit	Test Method	MDL	Results
Monobromobiphenyl	mg/kg	US EPA 3540C, GC/MS	5	N.D.
Dibromobiphenyl	mg/kg	US EPA 3540C, GC/MS	5	N.D.
Tribromobiphenyl	mg/kg	US EPA 3540C, GC/MS	5	N.D.
Tetrabromobiphenyl	mg/kg	US EPA 3540C, GC/MS	5	N.D.
Pentabromobiphenyl	mg/kg	US EPA 3540C, GC/MS	5	N.D.
Hexabromobiphenyl	mg/kg	US EPA 3540C, GC/MS	5	N.D.
Heptabromobiphenyl	mg/kg	US EPA 3540C, GC/MS	5	N.D.
Octabromobiphenyl	mg/kg	US EPA 3540C, GC/MS	5	N.D.
Nonabromobiphenyl	mg/kg	US EPA 3540C, GC/MS	5	N.D.
Decabromobiphenyl	mg/kg	US EPA 3540C, GC/MS	5	N.D.
Monobromodiphenyl ether	mg/kg	US EPA 3540C, GC/MS	5	N.D.
Dibromodiphenyl ether	mg/kg	US EPA 3540C, GC/MS	5	N.D.
Tribromodiphenyl ether	mg/kg	US EPA 3540C, GC/MS	5	N.D.
Tetrabromodiphenyl ether	mg/kg	US EPA 3540C, GC/MS	5	N.D.
Pentabromodiphenyl ether	mg/kg	US EPA 3540C, GC/MS	5	N.D.
Hexabromodiphenyl ether	mg/kg	US EPA 3540C, GC/MS	5	N.D.
Heptabromodiphenyl ether	mg/kg	US EPA 3540C, GC/MS	5	N.D.
Octabromodiphenyl ether	mg/kg	US EPA 3540C, GC/MS	5	N.D.
Nonabromodiphenyl ether	mg/kg	US EPA 3540C, GC/MS	5	N.D.
Decabromodiphenyl ether	mg/kg	US EPA 3540C, GC/MS	5	N.D.

- NOTE: (1) N.D. = Not detected.(<MDL)  
(2) ppm = mg/kg  
(3) MDL = Method Detection Limit  
(4) - = No regulation  
(5) \*\* = Qualitative analysis (No Unit)  
(6) Negative = Undetectable / Positive = Detectable

This Test Report is issued by the Company subject to its General Conditions of Service printed overleaf. Attention is drawn to the limitations of liability, indemnification and jurisdictional issues defined therein. The results shown in this test report refer only to the sample(s) tested unless otherwise stated. This Test Report cannot be reproduced, except in full, without prior written permission of the Company.

SGS Testing Korea Co., Ltd. 322, The D valley, 555-9, Hogeje-dong, Dongan-gu, Anyang-si, Gyeonggi-do, Korea 431-080  
t +82 (0)31 4608 000 f +82 (0)31 4608 059 www.sgslab.co.kr, www.kr.sgs.com/greenlab  
1002-2, Hwasan-ri, Onsan-eub, Uiju-gun, Ulsan, Korea 689-890 t +82 (0)52 239 6908-10 f +82 (0)52 239 6913

