

ZiVA™-4.1 Advanced DVD Decoder with Integrated Digital Video Encoder and Audio DSP

ZiVA 4.1

OVERVIEW

With the release of the ZiVA™-4.1 DVD decoder, LSI Logic again adds to its long list of technology innovations.

The fourth generation of LSI Logic's best-selling ZiVA product family integrates a digital video encoder and dedicated 50-MIPS audio DSP. The ZiVA-4.1 is the choice for implementing 3D audio, karaoke functions, and DVD-Audio in a cost-effective consumer DVD player. The ZiVA-4.1 further enriches the consumer's home theater and karaoke experience with its break-through RealSonic™ audio technology.

Fully compatible with previous ZiVA products, the ZiVA-4.1 decoder supports full disc playback compatibility with DVD, Chaoji VCD, VCD, and CD-DA formats.

With its high-level API implementation, the ZiVA-4.1 decoder simplifies system code development for DVD player design. OEMs realize shorter design cycles and faster time to market. In addition, OEMs can get comprehensive design support from LSI Logic.

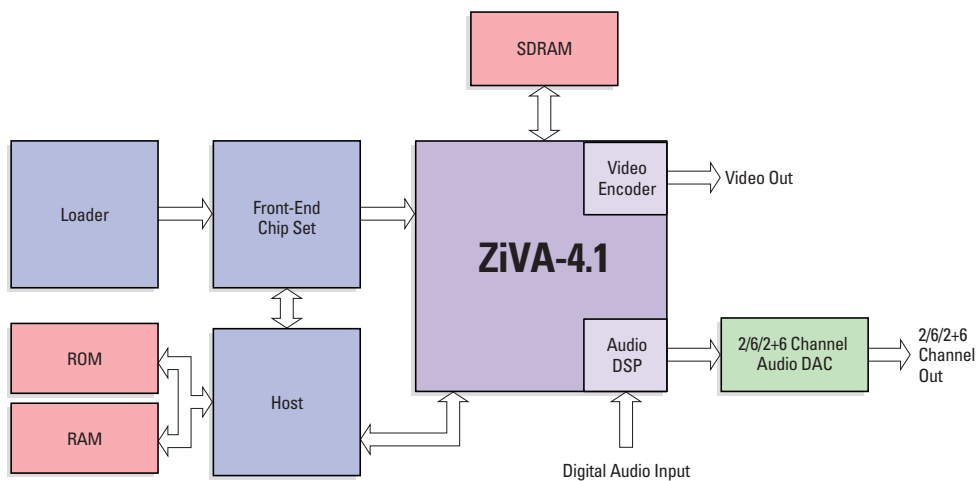

ZiVA™-4.1 Based DVD Player Architecture



FEATURES

- Full disc playback compatibility: DVD, Chaoji VCD, VCD, and CD-DA
- Embedded 10-bit, 4-DAC digital video encoder outputs YCbCr, RGB + composite sync (EuroSCART), or CVBS/S-video
- Supports NTSC, PAL, PAL-M, PAL-N, PAL-Nc, and PAL-60 (Q-PAL)
- Full NTSC and PAL decoding
- Dedicated 50-MIPS audio DSP delivering 3D audio, (including Spatializer™ N-2-2), DVD-Audio, Dolby Pro Logic™ decoding, Bass Redirection, RealSonic audio technology
- Dedicated Dolby Digital, MPEG-2 5.1-channel decoders
- MP3 Decoder
- DTS digital out
- 2/4-bits per pixel OSD
- Zoom and fade-in/-out functions for still and motion pictures



The
Communications
Company™

ZiVA™-4.1 Advanced DVD Decoder

MORE FEATURES

- LSI Logic's RealSonic audio technology allows royalty-free, high-quality home-theater audio effects, including:
 - Basic karaoke functions (mic echo, key control, stereo vocal cancel and voice detect)
 - Professional karaoke functions such as chorus, vocal harmony, scoring, flange, reverb, and simulated stereo
 - Home theater effects, including WideSound™, RealSonic concert hall, RealSonic dynamic range compression, and graphic equalizer
 - Phantom Virtual Surround Sound

Specifications	
Video	
Decoding Standards	MPEG-1, MPEG-2
Compressed	720 x 480 @ 30 Hz, 720 x 576 @ 25 Hz
Resolutions	480 x 576 @ 25 Hz 352 x 480 @ 30 Hz, 352 x 576 @ 25 Hz 352 x 240 @ 30 Hz, 352 x 288 @ 25 Hz
Formats	NTSC, PAL, CCIR 601, CCIR 656
Compatibility	DVD, Chaoji VCD, VideoCD, Personal Album
Audio	
Decoding Standards	Dolby Digital, MPEG-1 and MPEG-2 Layers 1, 2 and 3 (MP3), DVD-Audio LPCM, DVD-VideoLPCM, and CD-DA
Output Channels	Dolby Digital or MPEG-2; 2-channel (downmixed) and 5.1-channel PCM and IEC-1937/958 (SPDIF)
Sample Rates	44.1, 48, 88.2, 96, 176.4, 192 kHz
System	
Compressed Data Input	8-bit DVD, serial CD, or 8-bit host interface
Compressed Data Rate	16 Mbits/s (sustained, DVD interface); 80 Mbits/s (burst, host interface); 100+ Mbits/s (burst, DVD interface)
Physical	
Input Voltage	3.3V ± 5% (tolerates 5V inputs, except for SDRAM), 2.5V core logic
Packaging	Economical, low-profile 208-pin PQFP

For more information please call:

LSI Logic Corporation

North American Headquarters, Milpitas, CA
Tel: 800 574 4286

North America

Milpitas, CA
USA
Phone: 1-408-490-8000
Fax: 1-408-490-8590

Quebec, Canada
Phone: 1-514-426-5011
Fax: 1-514-426-7119

Europe

Crawley, West Sussex
United Kingdom
Phone: 44-1293-651100
Fax: 44-1293-651119

China

Beijing, China
Phone: 86-10-626-38296
Fax: 86-10-626-38322

Chengdu, China
Phone: 86-28-6713-150
Fax: 86-28-6713-694

Japan

Kohoku-Ku, Yokohama
Kanagawa Japan
Phone: 81-45-474-7571
Fax: 81-45-474-7570

Korea

Seoul, Korea
Phone: 822-561-9011
Fax: 822-561-9021

Taiwan

Taipei, Taiwan
Phone: 886-22-517-4938
Fax: 886-22-517-4937

LSI Logic logo design, ZiVA, RealSonic, and WideSound are trademarks of LSI Logic Corporation. All other brand and product names may be trademarks of their respective companies.

LSI Logic Corporation reserves the right to make changes to any products and services herein at any time without notice. LSI Logic does not assume any responsibility or liability arising out of the application or use of any product or service described herein, except as expressly agreed to in writing by LSI Logic; nor does the purchase, lease, or use of a product or service from LSI Logic convey a license under any patent rights, copyrights, trademark rights, or any other of the intellectual property rights of LSI Logic or of third parties.

Copyright ©2001 by LSI Logic Corporation.
All rights reserved.

Order No. I20072
1201.1K.XX.XX - Printed in USA



The
Communications
Company™